

St George

ST-ZTT-395

Concord Intelligent Toilet



WaterMark
AS/NZS 3718
WM-022958

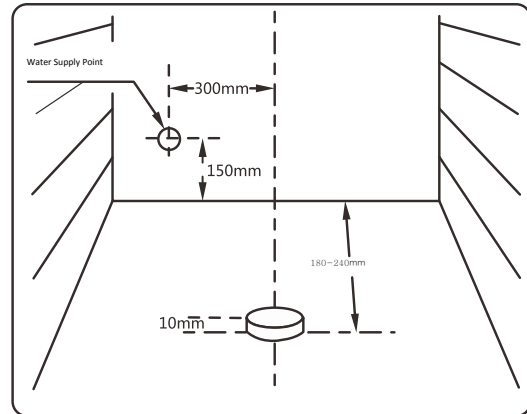
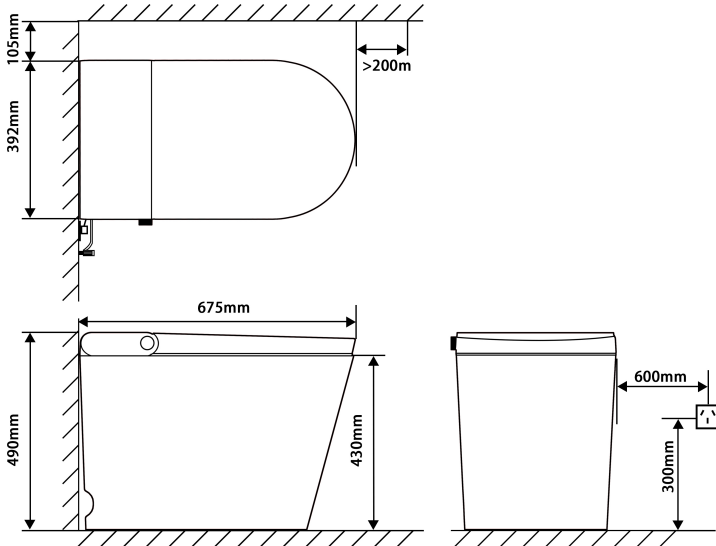

*Installation shall be in accordance with the AS/NZS 3500 series of standards.

Specifications

- Size : 675*392*490mm
- Working pressure : 200-500Kpa
- Applicable Voltage : AC 220-240V/50Hz
- Power: 1300W
- S Trap: 180mm - 240mm
- P Trap: 180mm
- WELS: 3.4L Average Flush (4 Stars)
- Powerpoint request

FEATURE

- Rear Cleansing
- Female Cleansing
- Adjustable Seat Temperature
- Dual Flush
- UV Nozzle Disinfect
- Comfortable Seat Height (470mm from floor to top of seat)
- Warm Air Dryer
- Premium Remote Controls
- Soft Nightlight
- Automatic Lid

*The Concord Intelligent Toilet ST-ZTT-395 complies with WMTS-051 and features an integrated Atmospheric Vacuum Breaker (AVB) that satisfies the high-hazard backflow prevention criteria of AS/NZ 3500.1 without the use of an RPZ valve.

ST GEORGE Care: For all sanitary ware products include a 15 Year ceramic replacement and 3 Years labour plus parts warranty* (Terms & Conditions Apply)

ST GEORGE 1800 272 828 | stgeorgegroup.com.au